



# Wireless receiver E25Q

## Mounting and operating instructions

(Translation of the original operating instructions)

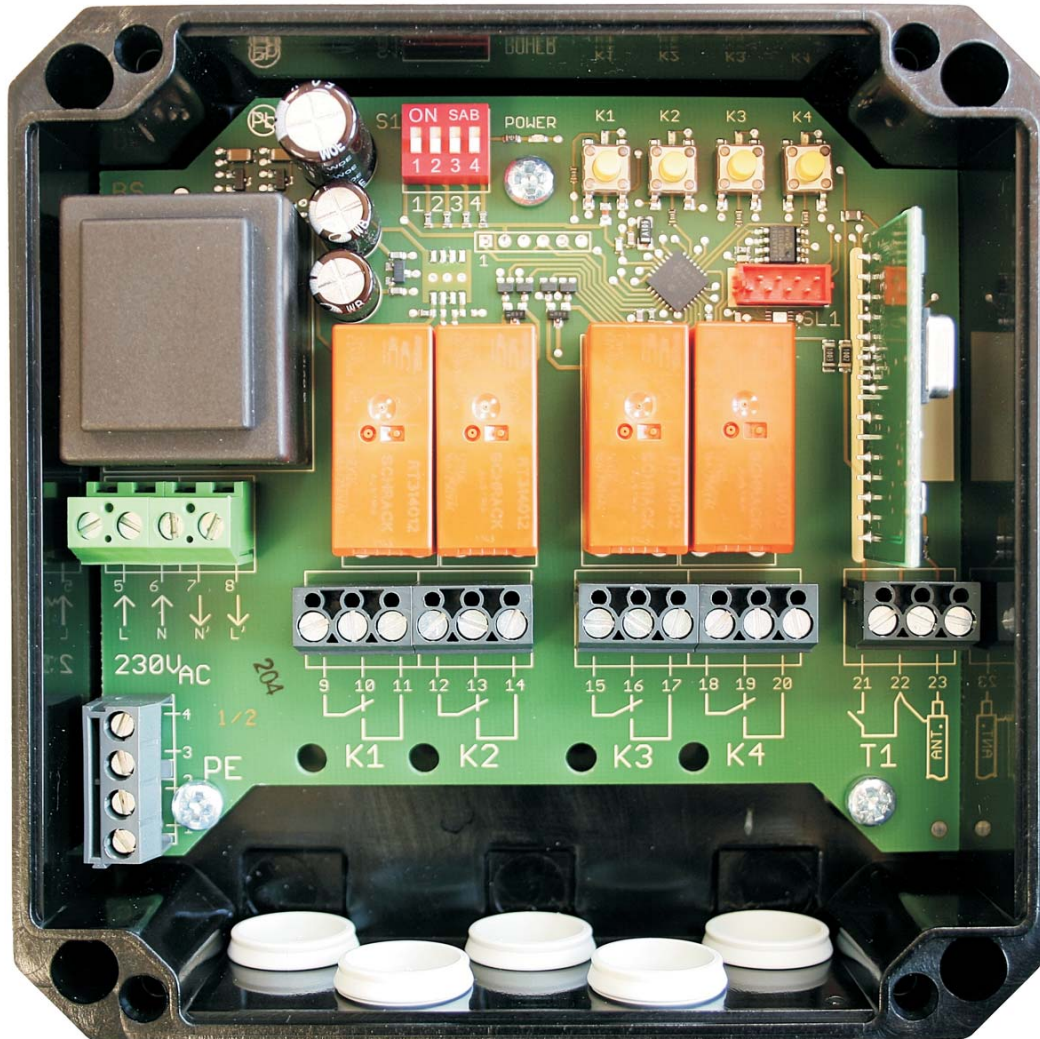

Photo: 230V Version



Function expansion/  
Data backup with  
QuickLog25



**Always read before initial operation!**

# Contents Parkeerapparatuur.nl

Data summary and functions.....	3
Scope.	
Functions.	
Function expansion	
Safety instructions.....	4
Symbols used.	
Basic safety instructions.	
Intended use .....	5
Use of wireless remote control units.	
Mounting instructions.	
Storage and transport conditions.	
Controls / Displays.....	6
Connection.....	7
Antenna installation	
Performance specification.....	8-9
Modes of operation.	
Transmit key / Teaching the key.	
Deleting codes.	
Teaching/deleting auto-off time	
Remote learning / Remote deleting.....	10-13
QuickLearn - Standard.	
QuickLearn - Group functions.	
Function expansion/Data backup.....	14-17
QuickLog25 Mounting	
Learning process when using as an awning control	
Backing up memory contents	
Restoring memory content	
Memory expansion	
Awning control with 2 switch relays	
Simple awning control with all-pole switch-off	
Dual awning control	
Frequency change.....	18
Technical data.....	18
Trouble shooting.....	18
Identifying the version.....	19
Environmental protection / Disposal.....	19
Declaration of conformity.....	19
Notes.....	20-22
Drilling pattern.....	23

# Data summary and functions

## Scope

Max. 4 potential-free, highly loadable relays in the output provide versatile applications. The receiver is ideal for switching lights, alarm systems, fountains, etc. An automatic shut-off time can be set for every output.

With ext. key or radio, the output can be switched off in advance or the switch-off time can be restarted. Suitable as a stairway light timer with a facility for "downstream switching".

## Functions

1- or 4-channel version in 27, 40, 433 or 868 Mhz

Frequency conversion through replaceable radio module

Operating voltage: 230 V/AC (optional 12 V AC/DC or 24 V AC/DC)

Standby under 0.5 watt.

Modes of operation: *Pulse, current surge, specific ON, specific OFF*

"Auto-Off" adjustable from 1 second up to approx. 18 hours

Input for external keys learnable on every channel

Relay output, potential-free

QuickLearn (remote learning)

## Function expansion/Data backup

Expand by using the optional add-on plug-in card QuickLog25

- Doubles the memory capacity of previously taught transmitters.
- Awning, roller blind or screen control with or without all-pole switch off,
- Control of two awnings without safety relevance.



Please keep these instructions so that you have them available if you have any questions later.

# Safety instructions

## Symbols used

**WARNING!**

Indication of imminent hazard. Non-compliance can lead to severe or fatal injuries and property damage.

**WARNING!**

Indication of imminent hazard. Non-compliance can lead to failure, destruction and property damage.

**WARNING!**

Indication of imminent electric shock. Non-compliance can lead to severe or fatal injuries.

**Information / Instruction****ESD-hazard**

Static electricity can lead to an immediate failure or later failure of the control unit.

## Basic safety instructions

### Working on the control

- Switch off supply voltage!
- Only switch the voltage on again after you have checked all the connections again.

### Mounting, installation, commissioning and maintenance

- Solely by specialists, e.g. by a qualified electrician who can judge the work-safety conditions.
- Based on the directives and the accepted rules of engineering.

### Operation

- The remote control of devices and systems which involve an increased risk of accident (e.g. crane systems) is prohibited!
  - Observe locally applicable regulations
  - Heed accident prevention regulations, VDE and electricity generating company regulations.
  - Information can be obtained from power stations, VDE and employers' liability insurance companies.
  - Technical modifications prohibited.
- Any change will result in a loss of liability and warranty.

- Reliable operation is only possible with careful mounting and installation according to these instructions. No guarantee or liability is assumed for damages which arise from



Disregarding these safety instructions can lead to personal and property damage!

## Use as intended

### Use of wireless remote control units

These remote control units are only approved for use with devices and systems where a functional problem in the transmitter or receiver does not result in a hazard for people, animals or property hazard or this risk is covered by other safety equipment. The user must be informed that the wireless remote control of systems with a risk of accidents is only permissible, if at all, with direct eye contact to the system and when the motion range is free of people, animals and objects. Store the hand-held transmitter so that unwanted activation, e.g. by children or animals, is impossible. The wireless remote control units in use work on generally-approved frequencies (ISM bands). The operator of such wireless remote control units is not protected from faults caused by other wireless systems or devices (e.g., wireless systems being operated in the same frequency range such as baby phones, intercoms, etc.).

### Mounting instructions



**Disregarding these mounting instructions can lead to personal and property damage!**

Increased interior temperature through direct sun radiation reduces service life.

Water or insects inside the control unit lead to failure or destruction.

To avoid damage to the control unit:

- Protect the control unit from influences of the weather.
- Only mount with housing.
- Use the fastening holes in the chambers of the cover screws. (Drilling patten see Page 23)
- To prevent housing deformation and leaks, mount on a flat surface, only tighten screws moderately.
- Mount in an upright position, cable feed from below.
- Open the self-sealing grommet using a round screwdriver. Do not cut open with a blade!

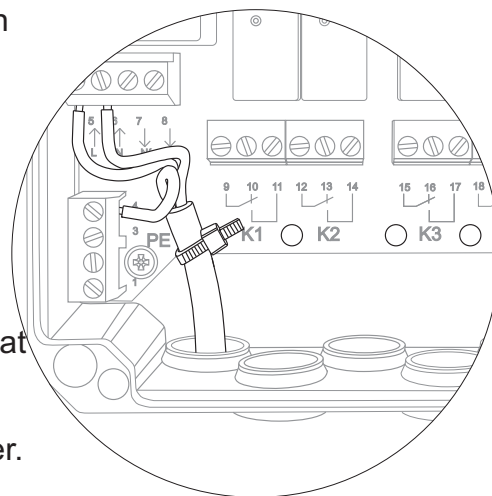

**With the help of a cable tie, you can use the four holes on the edge of the printed circuit board for strain relief of the connection wires.**

### Storage and transport conditions

*Disregard can lead to failure, even after initial operation!*

Store dry, dust-free and secure against impact and falling.

Storage temperature -20°C...+80°C at 30 %...60 % rel. humidity.

Transport only with sufficient and well-padded additional packaging.

- The existing packaging is not designed as transport packaging.
- Damage caused by disregard is not covered by the warranty!



# Controls / Displays

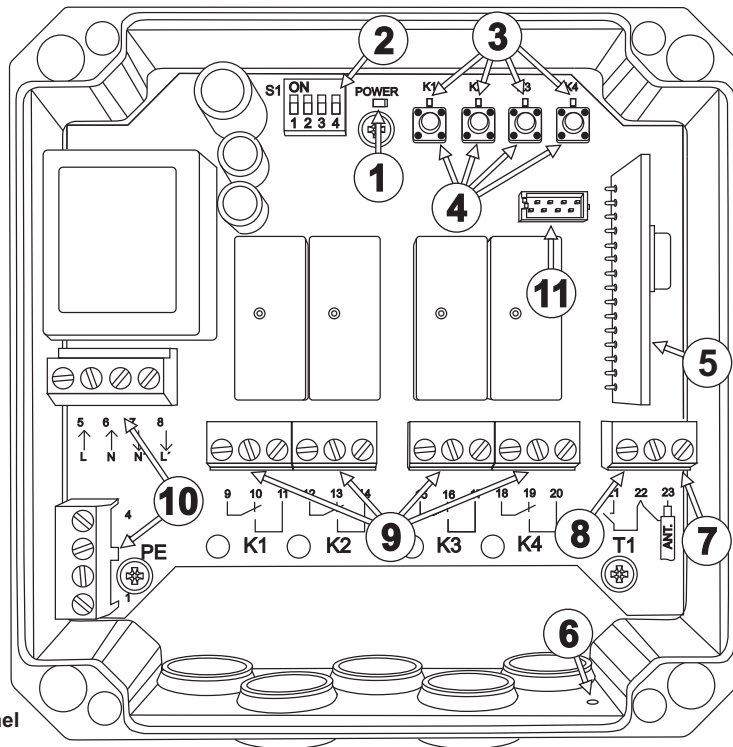

Fig. 4-channel

- ① **LED-POWER**  
flashes with operating voltage applied, flickers during deleting.
- ② **“Auto-Off” switch** (1= Channel 1, 2= Channel 2, 3= Channel 3, 4= Channel 4)  
The dip switches are used to teach the “Auto-Off” times (Page 9).  
When using as an awning control, the slat setting and the runtime can be set with the dip switch (Page 15).  
In the 1-channel version, the switches 2...4 do not have any function.
- ③ **LED’s “OUT”**  
- flash during teaching.  
- During operation they indicate the channel state (relay on/off).  
- Flickering during delete or when the radio signal of a previously taught transmitter is being received.
- ④ **“SET” key**  
for teaching and deleting transmitters or external keys (Page 8)
- ⑤ **Radio module slot**  
For description please refer to Page 18.
- ⑥ **Antenna hole**  
Bushing for the cube
- ⑦ **Antenna connection.**  
For connecting a cube or external antenna. Pay attention to ground / outer casing when connecting a coaxial cable.
- ⑧ **Key**  
For connecting an external key.  
Connect solely potential-free keys.
- ⑨ **Relay outputs**  
For connecting the consumer. One each changeover contact per channel.
- ⑩ **Mains connection**  
L´ and N´ have the same potential as L and N. For internal interconnection.
- ⑪ **Expansion slot**  
See page 14 for description.

# Connection



Work on the control unit may only be carried out with the device voltage-free! Danger of death due to electric shock! Non-compliance can lead to severe or fatal injuries.

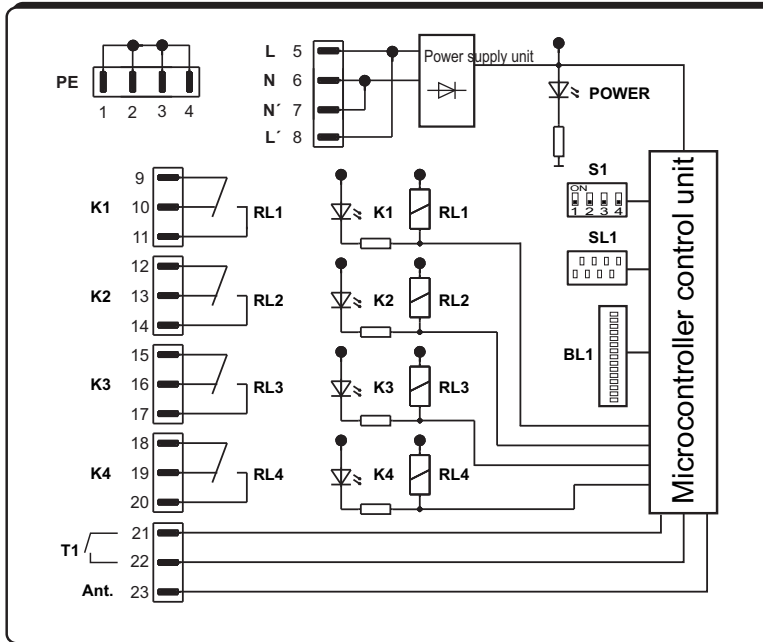

! Operating voltage depending on the version:  
● See rating plate

## Connection terminals

- 5 + 6 - Operating voltage according to rating plate
- 7 + 8 - Operating voltage for interconnection
- 1 + 2 + 3 + 4 - PE connection
- 9 + 10 + 11 - Relay output K1
- 12 + 13 + 14 - Relay output K2
- 15 + 16 + 17 - Relay output K3
- 18 + 19 + 20 - Relay output K4
- 21 + 22 - Key T1, potential-free
- 22 - Antenna connection ground
- 23 - Antenna connection

## Slots and displays

- BL1 - Radio module
- SL1 - Expansion module
- S1 - "Auto-Off" switch
- LED POWER - Power lamp
- LED OUT K1 - Channel 1 output
- LED OUT K2 - Channel 2 output
- LED OUT K3 - Channel 3 output
- LED OUT K4 - Channel 4 output

## Connection

Connect in accordance with the table and comply with the local regulations such as VDE, electricity generating company, etc. Various consumers can be connected to Terminals "K1...K4" (see technical data P. 16). The relays are subdivided into two blocks: K1, K2 and K3, K4 Mixed level operation with very-low voltage and mains voltage is possible between the two blocks. Mixed level operation within one block is prohibited. Terminals 21 + 22 are provided for potential-free keys (closers).

### **Never switch external voltage to Terminals 21, 22 or 23.**

The receiver will be immediately destroyed if this is not complied with! This will also void the guarantee! Connect the cube antenna to Terminal 23 and lead it out of the housing through hole "Pos. 6" (see Page 6).

## Antenna installation

- Do not install the antenna alongside cables, metal bodies or lighting equipment!
- Do not fasten the antenna end with or to metallic objects.
- To achieve the best range the antenna must be routed in its entire length.

# Performance specification



Care must be taken that grounding is in line with ESD requirements during all work on the control unit. Otherwise the control unit could be damaged or destroyed.

Maximum 100 transmitters can be taught. If 100 transmitters have already been taught in the receiver, no additional ones will be taught in addition; the previously learned codes are not lost. The first transmitter that is taught determines which coding scheme is valid. Either 12 bits, 18 bits or Keeloq transmitter can be taught. That means if the first detected coding was, e.g., 18 bits, only transmitters with 18-bit coding can be taught. After deleting all transmitters, another coding can be learned. Every transmitter key can be assigned all channels with different operating modes. For instance any key can control “Specific off” for **all** channels. To accomplish that, the channels must be simultaneously put into the learning mode. The same applies to external keys.

## Modes of operation

**Pulse:** The output switches as long as the selected transmitter key is pressed.

**Current surge:** The state of the output changes every time the transmitter key is pressed.

**Specific on/off:** A transmitter key is assigned the function “on” or “off”.

## Transmitter key / Teaching the key

Mode of operation	Programming	Display LED “OUT”
<b>Pulse</b>	Briefly push the “SET” key 1 x Press the transmitter key for 3 s	flashes 1 x - Pause - flashes 1 x ... flickers
<b>Surge current</b>	Briefly push the “SET” key 2 x Press the transmitter key for 3 s	flashes 2 x - Pause - flashes 2 x ... flickers
<b>Specific on</b>	Briefly push the “SET” key 3 x Press the transmitter key for 3 s	flashes 3 x - Pause - flashes 3 x ... flickers
<b>Specific off</b>	Briefly push the “SET” key 4 x Press the transmitter key for 3 s	flashes 4 x - Pause - flashes 4 x ... flickers

If the radio signal is detected, the LED “OUT” Pos. 3 flickers and the output switches. The key input is taught the same as a radio channel. Select the operating mode with the “SET” key of the desired channel, then press the connected key.



“Unsymmetrical” coding must be set in transmitters which have a coding switch! All coding switches set to “ON” or “OFF” leads to a loss of function or malfunctions.



## Deleting codes

### Delete wireless:

Press a "SET" key until the "OUT" LED's change from "flashing" into "Off". All learned codes will be deleted! It is not possible to delete individual codes.

### Delete key:

Keep the key pressed, press any "SET" key until the "OUT" LED's change from "flashing" to "Off".

## Teaching / deleting Auto-off time

Use Dip-switches 1...4 (see Page 6, Pos.2) to set the "Auto-Off" time separately for each channel. Dip switch in initial position disables the function.



The operating mode "Current Surge" or "Specific On" must be learned for "Auto-Off".

### Example:

Channel 1 is to switch off after 3 minutes. Dip-switch 1 must be in the lower position. Switch Channel 1 on with the key or via wireless. After 3 min set Dip-switch 1 to "ON" and leave it there. The channel switches off, the "Auto-Off" time is learned. In the "Specific On" operating mode, pressing the it again resets the time. Use "Pulse", "Current Surge" and "Specific OFF" to prematurely switch off. The time can be learned in intervals of one second in the range of 1 second to approx. 18 hours.

# Remote learning/Remote deleting

In connection with the hand-held transmitters of the Q-series, this function permits teaching additional transmitters or transmitter keys and also allows removing previously learned codes without direct access to the receiver. During this process, a master transmitter takes care of the remote control. In addition, the S8Q group transmitter has five group functions which you can assign with various functions or terminal equipment at will. The sixth group function applies to all groups. That facilitates both individual as well as group control of various devices.



## QuickLearn - Standard

A simple method for teaching additional transmitters (transmitter key) in the receiver.

### Teach one key:

This is to assign an additional transmitter (transmit key) with the same channel and the same function as the master transmitter (master key).

## QuickLearn - Group functions

Furthermore, the S8Q-..15.. has an expanded QuickLearn function which enables additional functions.

### Teach one key:

This is to assign an additional transmitter (transmit key) with the same channel and the same function as the master transmitter (master key).

### Teach one group:

This is to assign an additional transmitter (group) with the same channels as the master transmitter (master group).

### Delete one key:

One key is deleted.

### Delete one group:

One or all groups are deleted.

### Delete all except the master:

All transmitters and groups are deleted except the current master.

### Undo last learning process:

The most recent learning process can be undone within 5 minutes. A delete process cannot be undone.



**A transmitter that is taught directly on the receiver through the SET keys applies as a master. One receiver can have several masters. If all transmitters except the master are deleted, all masters except the current one are also deleted. A deletion process through the SET keys deletes all transmitters; deleting individual codes is not possible. Transmitters that only have the QuickLearn standard function as masters have the learning function for one key only. No delete function and no group function.**

## QuickLearn - Standard

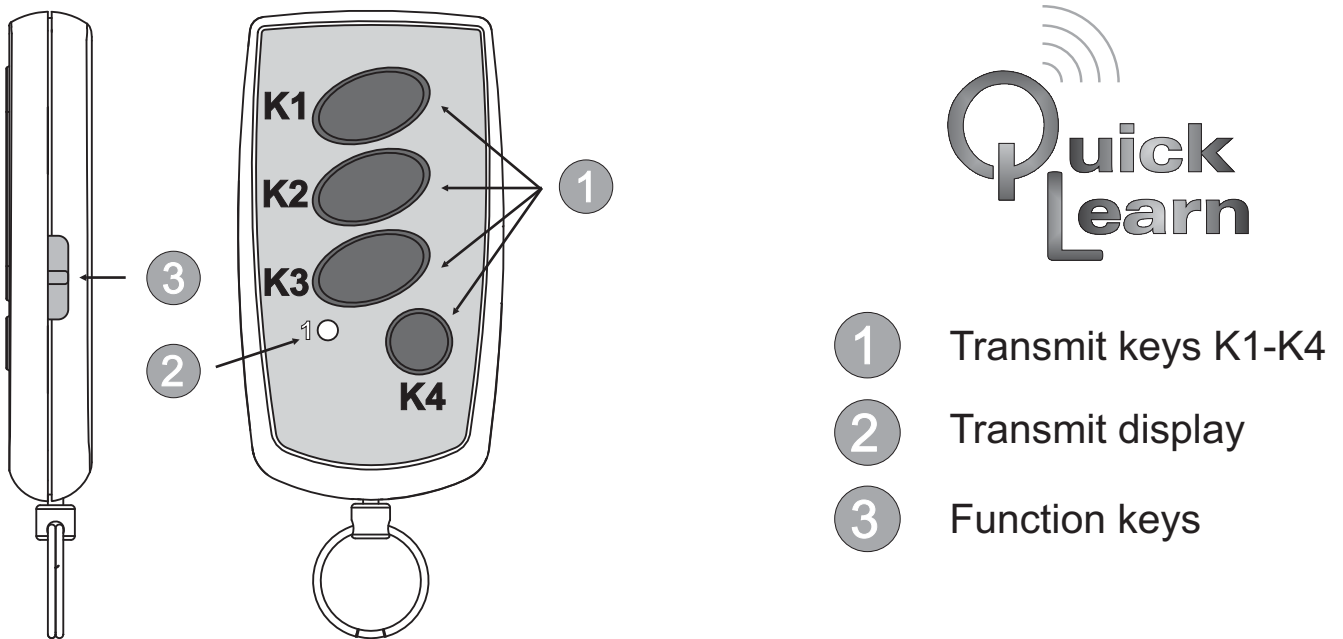

Fig.: S8Q-..04.. (4-channel transmitter)



A hand-held transmitter that has already been taught through the SET keys is designated as a master, as a slave of the hand-held transmitter to be newly taught; these terms are used again below.

Teaching one key		
Operation	S8Q-..04.. (4-channel transmitter)	E25Q receiver
Master Press the function key <3sec.	The transmit indicator flashes	
Master Press the transmit key to be copied	The transmit indicator flashes quickly	The learning OUT LED flashes, Learning mode
Slave Press the transmit key on the slave to be taught		The learning OUT LED flickers, the transmit key has been taught



These instructions apply representatively to all transmitters of the Q series which have a QuickLearn standard function.

**QuickLearn - Group functions**

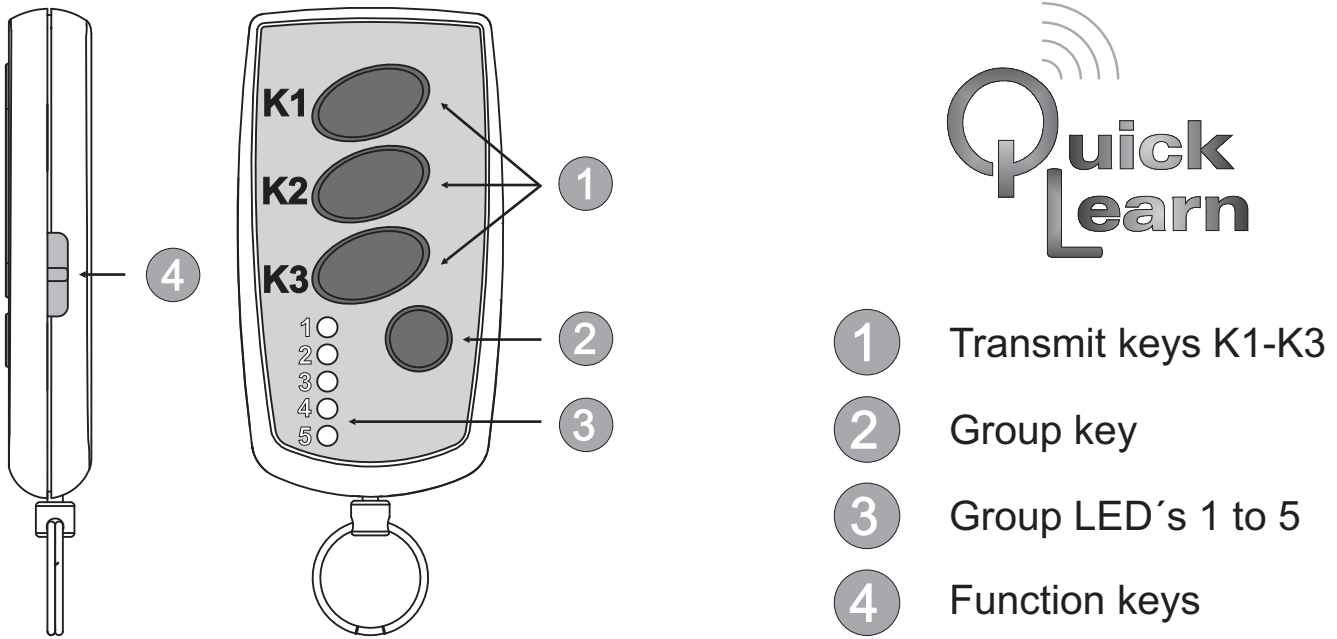



Fig.: S8Q-..15.. (Group transmitter)

 **A hand-held transmitter that has already been taught through the SET keys is designated as a master, as a slave of the hand-held transmitter to be newly taught. In all QuickLearn group functions, a previously taught group must be preselected on the master hand-held transmitter.**

Teaching one key		
Operation	S8Q-..15.. (Group transmitter)	E25Q receiver
Master Press the function key <3sec.	All group LED's are on, selected group flashes	
Master Select the group, press the transmit key to be copied	With K1, LED's 1 to 3 are illuminated With K2, LED's 2 to 4 are illuminated With K3, LED's 3 to 5 are illuminated	The learning OUT LED flashes, Learning mode
Slave Press the transmit key on the slave to be taught		The learning OUT LED flickers, the transmit key has been taught

Teaching one group		
Operation	S8Q-..15.. (Group transmitter)	E25Q receiver
Master Press the function key <3sec.	All group LED's are on, selected group flashes	
Master Select the group, press the group key (>2 sec.)	All group LED's on, selected group flashes 2x	LED's OUT K1 to K4 flash successively, learning mode
Slave Select the group to be taught, press any transmit key		LED's OUT K1 to K4 flicker, the group has been taught

**Undo the most recent learning process (only within 5 minutes)**

Operation	S8Q-..15.. (Group transmitter)	E25Q receiver
Master Select the taught group, Press the function key <3sec.	All group LED's are on, selected group flashes	
Master Press the function key (>3sec).	Group LED's 1, 3, 5 are on	
Master Keep group key pressed (>5 sec.)	Group LED's 1 to 5 illuminate successively; after that the group LED's 1,5 and 2,4 flash alternately	LED's OUT K1 to K4 flicker, The most recent command is invalid

**Deleting one key**

Operation	S8Q-..15.. (Group transmitter)	E25Q receiver
Master Select the taught group, Press the function key >10sec.	LED's from 1 to 5 extinguish successively; after that they successively turn on from 5 to 1; then all LED's flicker	
Master Press any transmit key	LED's 2 and 4 flicker	LED's OUT K1 to K4 flicker
Slave Press the key to be deleted		LED's OUT K1 to K4 off

**Deleting one group**

Operation	S8Q-..15.. (Group transmitter)	E25Q receiver
Master Select the taught group, Press the function key >10sec.	LED's from 1 to 5 extinguish successively; after that they successively turn on from 5 to 1; then all LED's flicker	
Master Press the group key	LED 3 off, LED1,2,4 and 5 flicker	LED's OUT K1 to K4 flicker
Slave Select the group to be deleted, press any transmit key		LED's OUT K1 to K4 off

**Deleting all except the master**

Operation	S8Q-..15.. (Group transmitter)	E25Q receiver
Master Select the taught group, Press the function key >10sec.	LED's from 1 to 5 extinguish successively; after that they successively turn on from 5 to 1; then all LED's flicker	
Master Press the function key again (>3 sec.)	LED's 1,3,5 flicker	
Master Press the group key (>5 sec.)	LED's illuminate consecutively from 1 to 5; then LED's 1, 5 and 2,4 flash alternately	LED's OUT K1 to K4 flicker

# Function expansion/Data backup

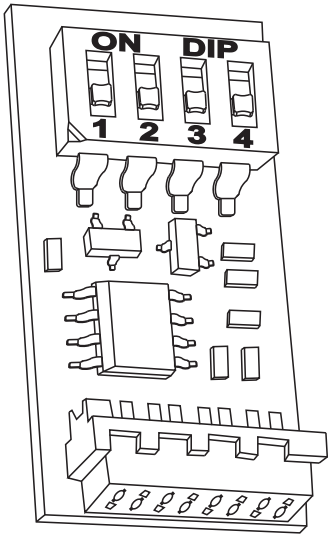

You can expand the wireless receiver with the **QuickLog25** plug-in card. That means it can expand the maximum memory capacity from max. 100 learnable codes (transmitter key) to max. 200 codes, it can back up the learned codes to the plug-in card, it can restore previously backed-up codes or can implement control of, e.g., roller blinds, awnings or screens with additional switched outputs, with or without all-pole shut-down (N conductor switched).

Select the desired function with the aid of the DIP1 to DIP3 coding switches on the add-on card. The fourth coding switch, DIP4, is used as write protection. The selected function is implemented when mains voltage is applied.

Switch position				Expanded function
DIP1	DIP2	DIP3	DIP4	
OFF	OFF	OFF	ON	No function expansion, write protection on.
ON	OFF	OFF	OFF	Backup the memory content to the plug-in card
OFF	ON	OFF	ON	Restore memory content from the plug-in card
ON	ON	OFF	ON	Memory expansion from 100 to 200 codes
OFF	OFF	ON	ON	Awning control with 2 switching relays
ON	OFF	ON	ON	Awning control with switched N and 1 switching relay
OFF	ON	ON	ON	Dual awning control

## QuickLog25 Mounting

- Select the function, set the DIP switch.
- Switch off the power supply!
- Insert the plug-in card *“the right way round”* into the expansion slot *“Pos. 11”* (see Page 6).
- Switch on power supply voltage.

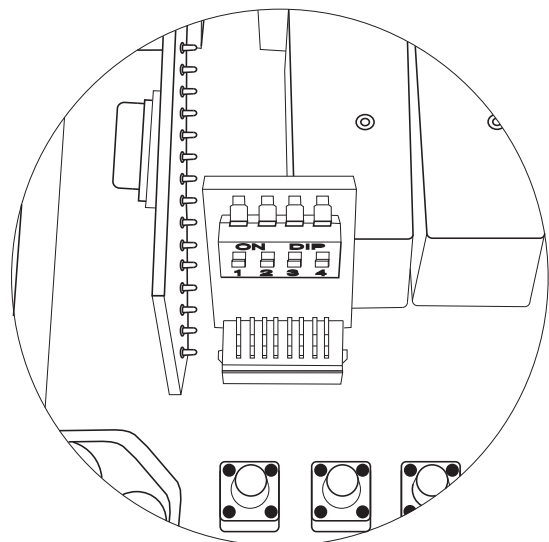



## Learning process when using as an awning control unit

To use the awning function, the hand-held transmitter must be taught in a special manner, depending on the defined operating mode on the related channel.

**With dual awning control, Channel 3 is programmed corresponding to Channel 1 and Channel 4 is programmed corresponding to Channel 2.**

	Programming Channel 1	Display LED "OUT"
<b>Pulse</b>	Briefly push the "SET1" key 1 x Press the transmitter key for 3 s	flashes 1 x - Pause - flashes 1 x ... flickers
<b>UP</b> (with panic)	Briefly push the "SET1" key 2 x Press the transmitter key for 3 s	flashes 2 x - Pause - flashes 2 x ... flickers
<b>UP</b> (Dead man)	Briefly push the "SET1" key 3 x Press the transmitter key for 3 s	flashes 3 x - Pause - flashes 3 x ... flickers
<b>UP</b> (without panic)	Briefly push the "SET1" key 4 x Press the transmitter key for 3 s	flashes 4 x - Pause - flashes 4 x ... flickers

Mode of operation	Programming Channel 2	Display LED "OUT"
<b>STOP</b>	Briefly push the "SET2" key 1 x Press the transmitter key for 3 s	flashes 1 x - Pause - flashes 1 x ... flickers
<b>CLOSED</b> (with panic)	Briefly push the "SET2" key 2 x Press the transmitter key for 3 s	flashes 2 x - Pause - flashes 2 x ... flickers
<b>CLOSED</b> (Dead man)	Briefly push the "SET2" key 3 x Press the transmitter key for 3 s	flashes 3 x - Pause - flashes 3 x ... flickers
<b>CLOSED</b> (without panic)	Briefly push the "SET2" key 4 x Press the transmitter key for 3 s	flashes 4 x - Pause - flashes 4 x ... flickers

The switches Auto-Off DIP1-DIP2, respectively DIP3-DIP4 "Pos. 2" (see Page 6) on dual awning control assume the function of the slat setting and the maximum runtime.

Switch Auto-Off	Operating mode
<b>DIP1: OFF</b>	Without slat setting
<b>DIP1: ON</b>	With slat setting
<b>DIP2: OFF</b>	Maximal runtime 120 sec.
<b>DIP2: ON</b>	Runtime taught.



**Dead man operating mode:** The output is switched as long as the selected transmitter key is pressed.

**Panic function:** While the motor is running, the next command always acts as a stop command.

**Slat setting:** if pressed for less than 1 sec., dead-man operation for setting the slats is implemented; the output only goes into self-holding if pressed for longer than 1 sec.

## Backup the memory content (DIP1=ON, DIP2-DIP4=OFF)

The data will be transmitted to the QuickLog25 plug-in card when the mains voltage is switched on. After a successful backup, the green POWER LED is permanently illuminated while the red LED OUT K1 flashes 5x. After that, the mains voltage can be switched off and the plug-in card can be removed for safe storage. Error display: If DIP4 is on ON (write protection), the POWER LED and LED OUT K1 flash together 4x. Check the DIP4 setting, repeat the process.

## Restore the memory content (DIP1=OFF, DIP2=ON, DIP3=OFF, DIP4=ON)

The data are transmitted back from the QuickLog25 plug-in card to the control unit when the mains voltage is switched on. After successful restoration, the red LED OUT K1 is permanently illuminated while the green LED-Power flashes 5x. After that, the mains voltage can be switched off and the plug-in card can be removed for safe storage. If there is no E25Q data on the add-on card, the POWER LED and the LED OUT K1 flash 4x together. Back transferring is only possible if the data from an E25Q control unit was backed up to this add-on card beforehand.

## Memory expansion (DIP1-DIP2=ON, DIP3=OFF, DIP4=ON)

The control unit can now be taught with 200 transmitter keys instead of 100 transmitter keys. With this operating mode, the add-on card must remain in the control unit.

## Awning control with 2 switching relays (DIP1-DIP2=OFF, DIP3-DIP4=ON)

K1 and K2 are used for the awning function

K1: Opening

K2: Closing

K3 and K4 continue to have normal wireless function



AC motor wiring: Relay K2 is wired through the opener from Relay K1. That means the up relay has precedence and the relays are blocked against each other.

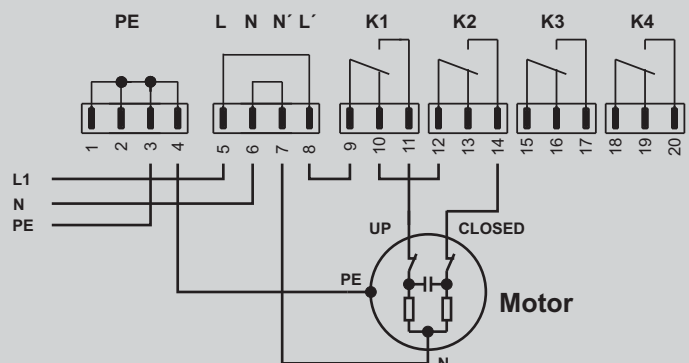

DC motor wiring: Minus on both closers, plus on both openers, motor on both together.

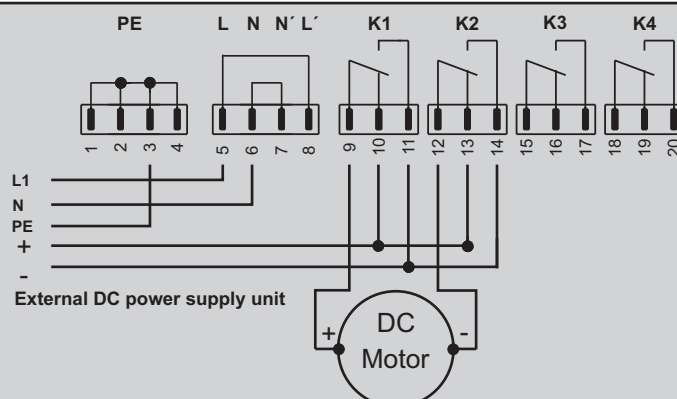

## Simple awning control with all-pole shut-down (DIP1=ON, DIP2=OFF, DIP3-DIP4=ON)

Channel 1, Channel 2 and Channel 3 are used for the awning function

K1: Opening

K2: Closing

K3: switched N

SET K3 key: no function

Auto-Off 3 switch: no function

K4 continues to have normal wireless function



AC motor wiring: Relay K2 is wired through the opener from Relay K1. That means the up relay has precedence and the relays are blocked against each other. N is wired through Relay K3 to all-pole shut-down.

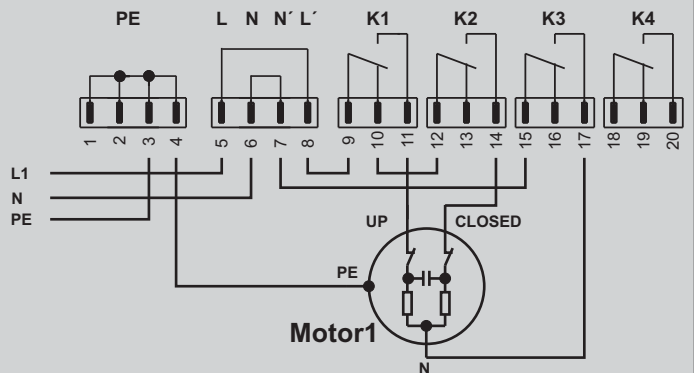

## Dual awning control (DIP1=OFF, DIP2-DIP4=ON)

Channel 1 and Channel 2 are used for the Awning 1 function

Channel 3 and Channel 4 are used for the Awning 2 function

K1 or K3: Opening

K2 or K4: Closing



Wiring of AC motors: Relay K2 is wired through the opener of Relay K1, Relay K4 is wired through the opener of Relay K3. That means the up relays have precedence and the relays are blocked against each other.

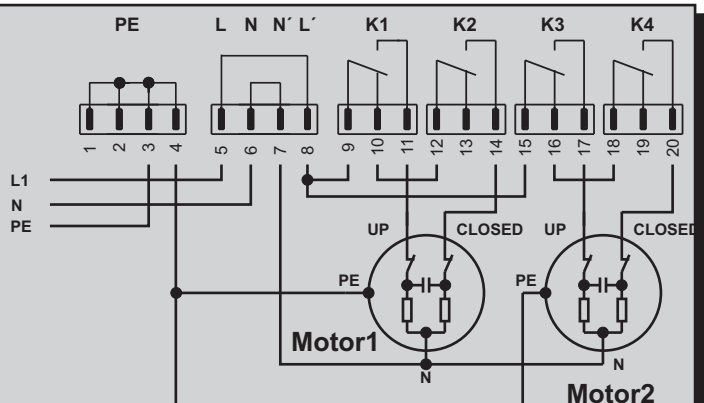

## Frequency change (replace radio module)

If problems occur in the frequency range being used, the receiver can be converted to a different frequency by replacing the radio module. The transmitter and radio module must have the same frequency and the same modulation, e.g. AM/FM. **Note the change on the rating plate**

- switch off supply voltage!
- Carefully pull the radio module out of the plug-in socket BL1 / "Pos. 5" (see Page 6).
- Insert the radio module with the required frequency "the right way round".
- Delete radio (see Page 9).
- Switch on supply voltage.
- Teach new transmitter.

## Technical data





<b>Frequency:</b>	- Radio module with 27MHz, 40MHz, 433MHz or 868MHz AM/FM	
<b>Coding:</b>	- 12 bit, 18 bit or Keeloq, self-teaching, max. 100 codes (transmitter keys) can be taught	
<b>Operating voltage:</b>	- 230V AC $\pm$ 10% 50Hz (optional 12V AC/DC or 24V AC/DC $\pm$ 10% 50Hz)	
<b>Power consumption:</b>	- Approx. 5W (all outputs switched on)	
<b>Standby:</b>	- <0.5W	
<b>Output:</b>	- 1 or 4 relays, 1xUM, potential-free, max. 250V AC 8A or max. 30V DC 8A (active load per output).	
<b>Connected load:</b>	- max. 2,000VA	
<b>Operating temperature:</b>	- -20° C...+50° C at 30 %...80 % rel. humidity	
<b>Dimensions:</b>	- 125 mm x 125 mm x 52 mm Housing plastic IP54	
<b>Weight:</b>	- Approx. 0.6 kg incl. packaging	

## Troubleshooting

<u>Error</u>	<u>Possible causes</u>	<u>Action</u>
POWER LED does not flash	- Operating voltage missing	- Check connection
Relay does not switch LED on transmitter and LED Power lamps but	- Transmitter was not taught - Frequency of transmitter and receiver not identical - Transmit key pressed too briefly - Transmitter defective - Receiver defective	- Teach transmitter - Use matching transmitter - Press key for at least 1 s to 2 s. - Check transmitter, replace if necessary - Check receiver, replace if necessary
Range too low	- Battery in hand-held transmitter too weak - Antenna not connected or poorly placed	- Check battery, replace if necessary - Maintain clearance to steel parts and electric lines

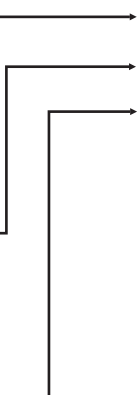
## Identify the version

The following rating plate serves as a sample. The actual data are on the rating plate glued to the outside on the receiver housing. The connected power supply voltage must be identical with the voltage stated on the rating plate.

<b>Order number:</b> <b>E25Q-40A 400</b> 1    2    3 1 = Basic type 2 = Frequency AM/FM 3 = Version		<b>4K wireless receiver</b> <b>E25Q-40A400</b> 2142 40.685 MHz AM <b>230V 50Hz 5W</b> 020101432 Connected load max. 2,000VA  <b>dickert®</b>  IP54  	Fig. sample rating plate
<b>Frequency:</b> e.g. 27.015MHz 40.685 MHz 433.92 MHz 868.30 Mhz			
<b>Operating voltage:</b> e.g. 230 V/AC 12 V AC/DC 24 V AC/DC			

## Environmental protection / Disposal

The control unit does not contain any integrated batteries. Solely ROHS-conform components are used. Properly dispose of old and defective appliances and device parts in a collecting point! Do not put them in domestic waste!



## Declaration of conformity

### Declaration of conformity Type E25Q:

The manufacturer herewith declares that the receiver meets the requirements in Directive R&TTE 1999/5/EC when used as intended. For further information please refer to the URL of the manufacturer stated on the unit.





## Notes



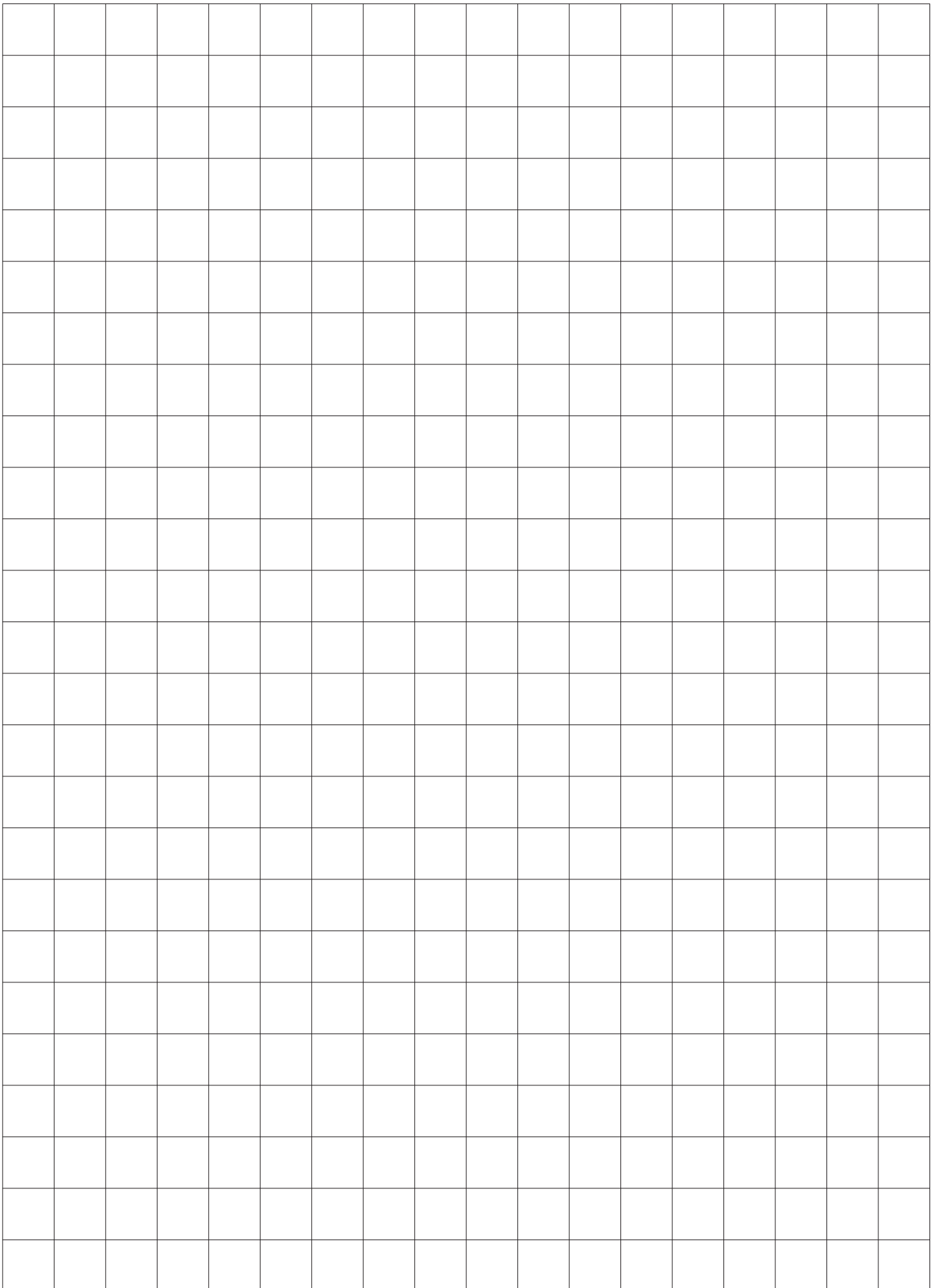

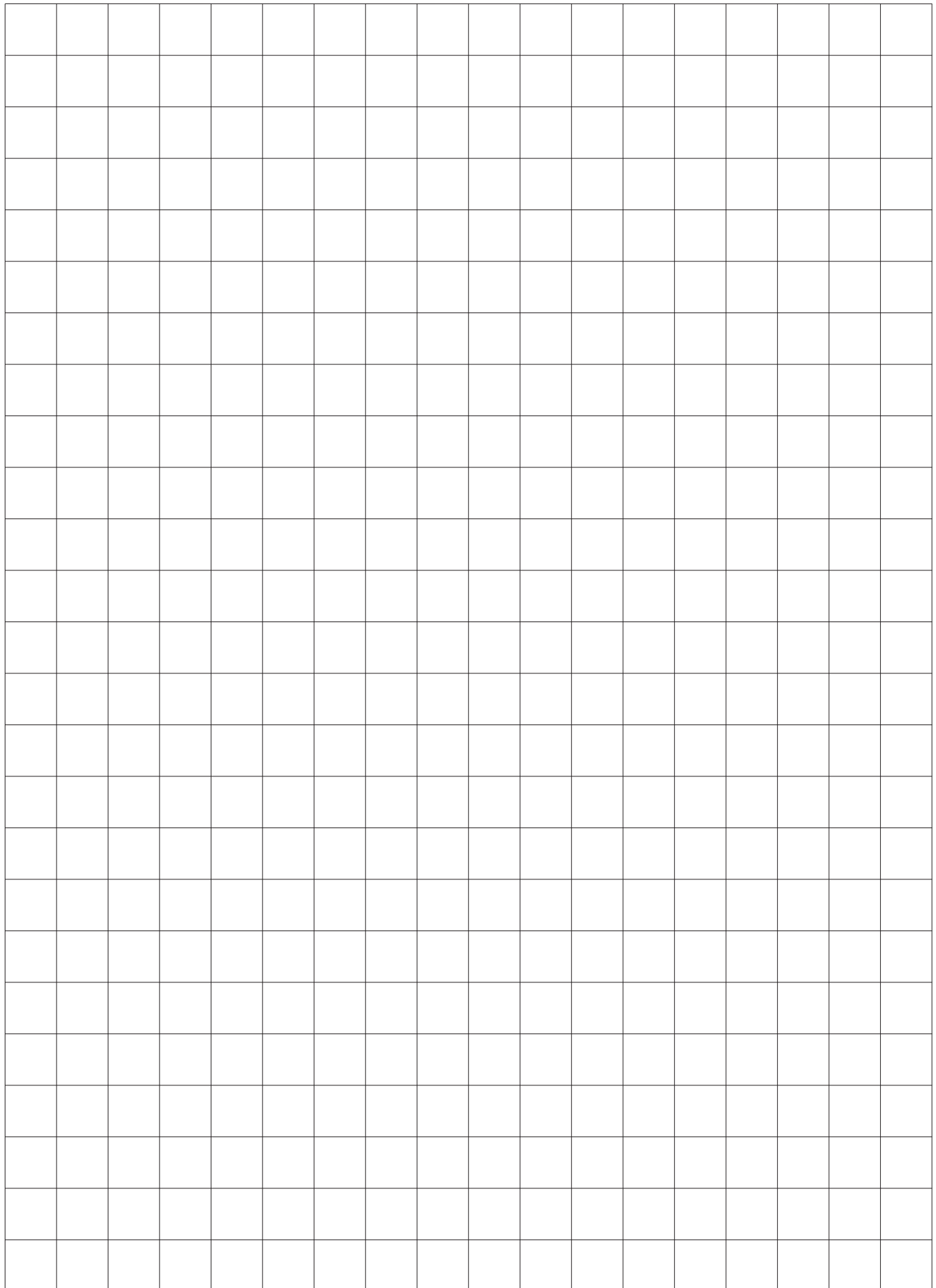
# Drilling pattern

for housing installation

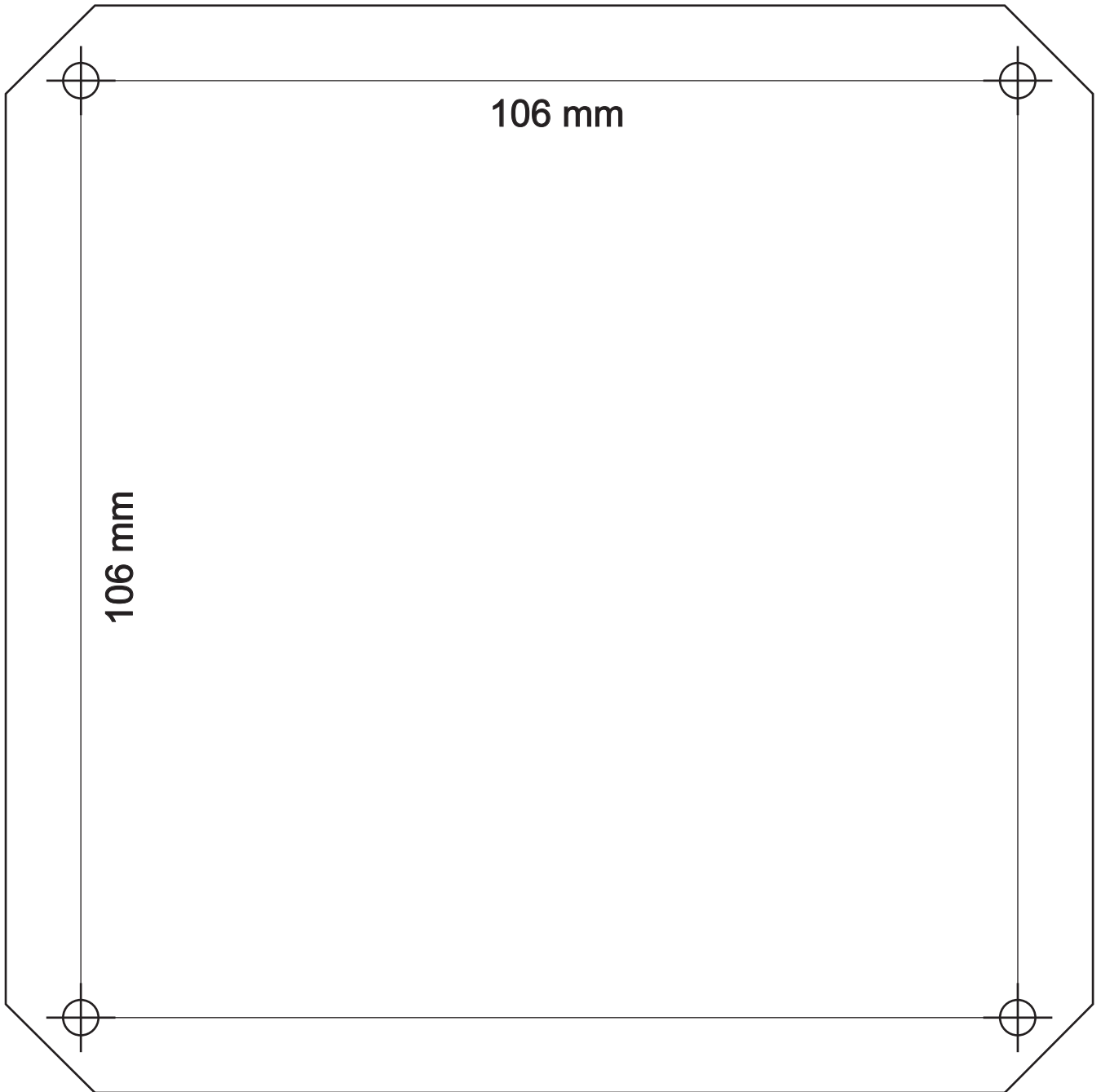

**Check the dimensional accuracy before using!**



